



A REPUTATION OF EXCELLENCE.....

.....A COMMITMENT TO INNOVATION

LP-300-54

Two Point Straight Side Press



OAK Press Solutions Inc.

504 Wade St.
Sturgis, MI, 49091 USA

Tel : 269-651-8513

Fax: 269-659-4625

E-mail: sales@oakpresses.com

Online: www.oakpresses.com



**A REPUTATION OF EXCELLENCE.....
.....A COMMITMENT TO INNOVATION**

LP-300-54

Design Features

Slide Lift System

Hydraulic withdrawl
Quick Change Tooling
Stuck on Bottom Recovery
Overload protection

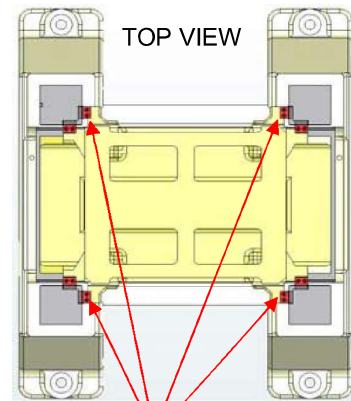
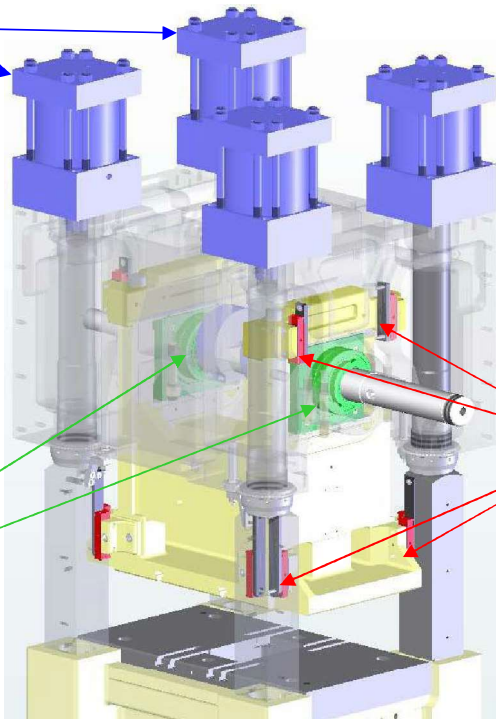

Guidance System

12 Point System
Anti-friction roller bearings
Zero clearance gibs
Large effective bearing area

Drive System

Anti-friction roller bearings
"Scotch Yoke" drive assembly

Drive System

OAK presses use of anti-friction roller bearings on all driving components to provide superior precision, life, and speed compared to conventional bushings. The patented scotch yoke slide eliminates connecting rods and places 90 % of the die area between the driving mechanisms for superior off-center loading performance.

Guidance System

The LP series incorporates a 12 point guidance system on the slide. All gibs use anti-friction roller bearings installed with zero clearance. Gibs are located at extreme ends of the slide to provide maximum effective bearing area. This gives the slide a very high degree of accuracy for higher quality parts and longer tool life.

Slide Lift System (Hyd. Withdrawl)

The patented hydraulic withdrawl system will give you up to 5 inches of die separation without effecting the shutheight setting. This feature simplifies die inspection and tool maintenance.

Quick Change Tooling System

The hydraulic withdrawl system allows you to lift the complete die assembly off the bolster for easy and fast die change.

Stuck on Bottom Recovery

The hydraulic withdrawl system allows you to raise the slide independent of drive shaft position. This feature makes it impossible to stick the press on bottom dead center.

Automatic Lubrication System

An automatic lubrication system with progressive feeder manifolds ensures proper lubrication volumes to all driving and guidance systems on the press. This system also incorporates fault detection for low lube levels and lube point blockage.

OAK Press Solutions Inc.

504 Wade St.
Sturgis, MI, 49091 USA

Tel : 269-651-8513

Fax: 269-659-4625

E-mail: sales@oakpresses.com

Online: www.oakpresses.com



High-Speed Stamping Presses

A REPUTATION OF EXCELLENCE.....

.....A COMMITMENT TO INNOVATION

LP-300-54

Specifications

Technical Data	Imperial Rating	Units	Metric Rating	Units
Capacity	300	tons	2669	kN
Force Rating Distance	0.06	inches	1.52	mm
Stroke Length (max.)	3.00	inches	76.20	mm
Shut height (min) *	10.00	inches	254.00	mm
Shut height (max) *	14.00	inches	355.60	mm
Slide lift (hydraulic withdrawl)	6.00	inches	152.40	mm
Strokes per minute (min.)	133	SPM	133	SPM
Strokes per minute (max.)	400	SPM	400	SPM
Bolster area (left - right)	81.00	inches	2057.40	mm
Bolster area (front - back)	36.00	inches	914.40	mm
Bolster thickness	8.00	inches	203.20	mm
Bolster Height from floor	50.00	inches	1270.00	mm
Slide area (left - right)	61.12	inches	1552.45	mm
Slide area (front - back)	35.00	inches	889.00	mm
Die Loading area (left - right)	54.50	inches	1384.30	mm
Die Loading area (front - back)	37.00	inches	939.80	mm
Bed Opening area (left - right) **	48.00	inches	1219.20	mm
Bed Opening area (front -back) **	16.00	inches	406.40	mm
Floor Space (left - right)	82.50	inches	2095.50	mm
Floor Space (front - back)	88.00	inches	2235.20	mm
Height	176.00	inches	4470.40	mm
Weight	91400	pounds	41459	kg
Main Motor	50.00	HP	37.29	kW

* custom shut height available upon request.

** custom bed openings available upon request.

OAK Press Solutions Inc.

504 Wade St.
Sturgis, MI, 49091 USA

Tel : 269-651-8513

Fax: 269-659-4625

E-mail: sales@oakpresses.com

Online: www.oakpresses.com



High-Speed Stamping Presses

A REPUTATION OF EXCELLENCE.....

.....A COMMITMENT TO INNOVATION

LP-300-54

Dimensions

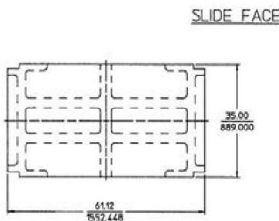
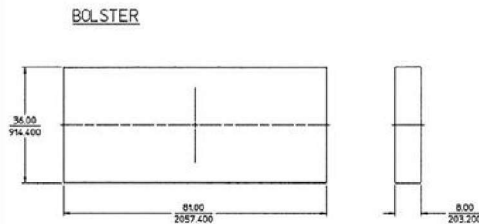
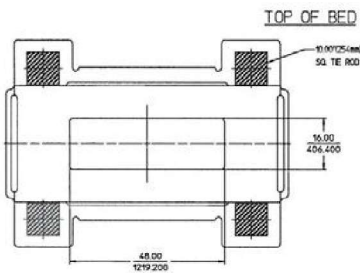
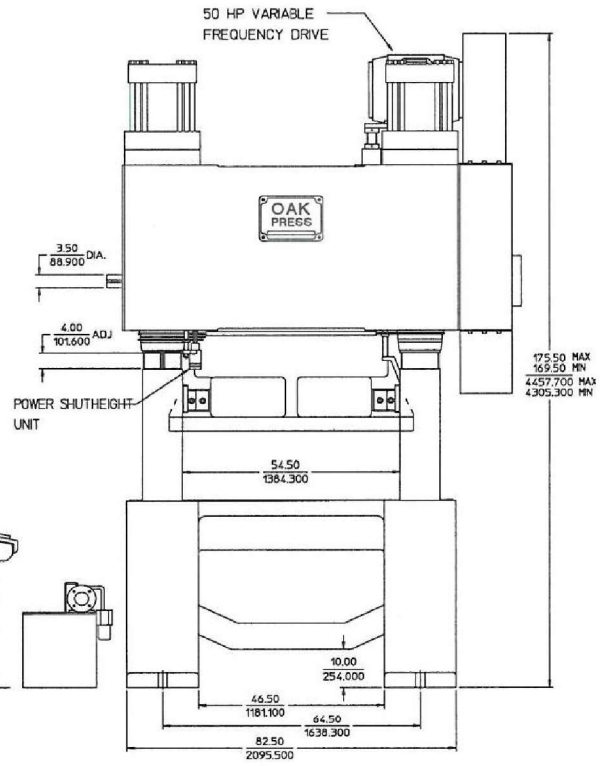
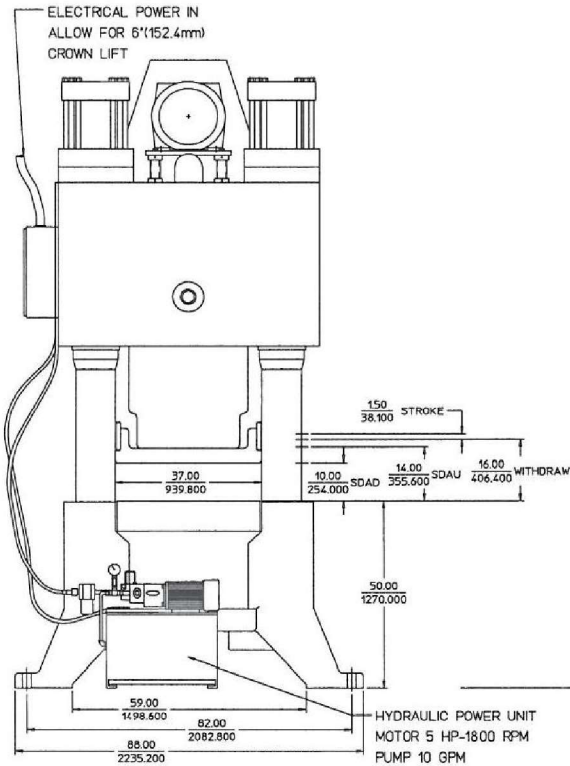

300 TON
 MAXIMUM STROKE 3.00"
 SPEED RANGE 133-300 SPM
 PRESS WGHT. 90,400#

OAK Press Solutions Inc.

504 Wade St.
Sturgis, MI, 49091 USA

Tel : 269-651-8513

Fax: 269-659-4625

E-mail: sales@oakpresses.com

Online: www.oakpresses.com